



- Wide range measurement from atmosphere to  $1.0E-5Pa$
- Support local and real time display
- Yttria coated iridium filament ensures long-term stable operation
- Temperature compensation to eliminate the interference of ambient
- Selectable display unit: Pa, Torr and mBar
- Support RS485 MODBUS data communication
- Support analog voltage signal output
- Support dual programmable setpoint relay outputs
- Support communication with PC application software GaugeReader

WPH 300 Pirani Hot Ion Combined Vacuum Gauge

## Operation Manual

## 1. Model Guidance

Integrated Digital Display Pirani Cold Cathode Vacuum Gauge

WPH 300 X (X for flange, A:KF25, B:KF40, C:CF25, D: CF35)

## 2. Specifications

Parameters	Technical Data
Measurement Range	$1.0 \times 10^{-5} \sim 1.0 \times 10^{+5}$ Pa (Air, N <sub>2</sub> )
Accuracy	$1.0 \times 10^{-5} \sim 1.0 \times 10^{-4}$ Pa : $\pm 35\%$
	$1.0 \times 10^{-4} \sim 1.0 \times 10^{+4}$ Pa : $\pm 25\%$
	$1.0 \times 10^{+4} \sim 1.0 \times 10^{+5}$ Pa : $\pm 50\%$
Repeatability	$1.0 \times 10^{-5} \sim 1.0 \times 10^{+3}$ Pa : $\pm 5\%$
	$1.0 \times 10^{+3} \sim 1.0 \times 10^{+5}$ Pa : $\pm 25\%$
Pressure withstand	Max. $1.5 \times 10^{+5}$ Pa
Response Time	Display Update: 1 sec   Analog Voltage < 100 ms
Working Environment	0 °C ~ +45 °C; 5 ~ 85 %, No Condensation
Storage Environment	-40 °C ~ +75 °C; 5 ~ 90 %, No Condensation
Signal Output	5-digit LED Display, Selectable Unit
	Dual Setpoint Control Relay Output, 60VDC 0.5A
	RS485, 9600 bps, Modbus RTU
	Analog Output +0.0V~+10.0VDC
Electrical Interface	DSub9 Male Socket
Power Supply	+16~+32 VDC /0.5A ; Max. 15W
Protection	IP40, IEC529
Vacuum Flange	Standard DN 25 ISO-KF; Others to be Customized
Weight and Size	550g (KF25); 130H X 60W X 50D (KF25)
Materials in Vacuum	SS304, Kovar, Tungsten, Glass

Note : Due to R & D and new product launch, INSTRUE reserves the right to modify this document. Please keep in touch with the original factory!

### 3. WPH 300: DBSub9 Pin Assignment

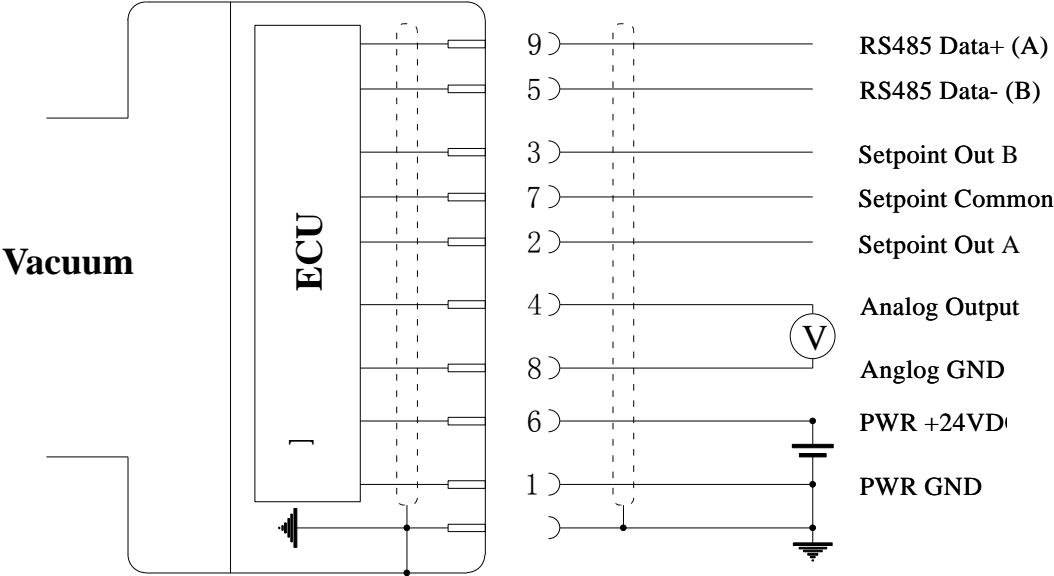

D-Sub 9, Female, Soldering Side

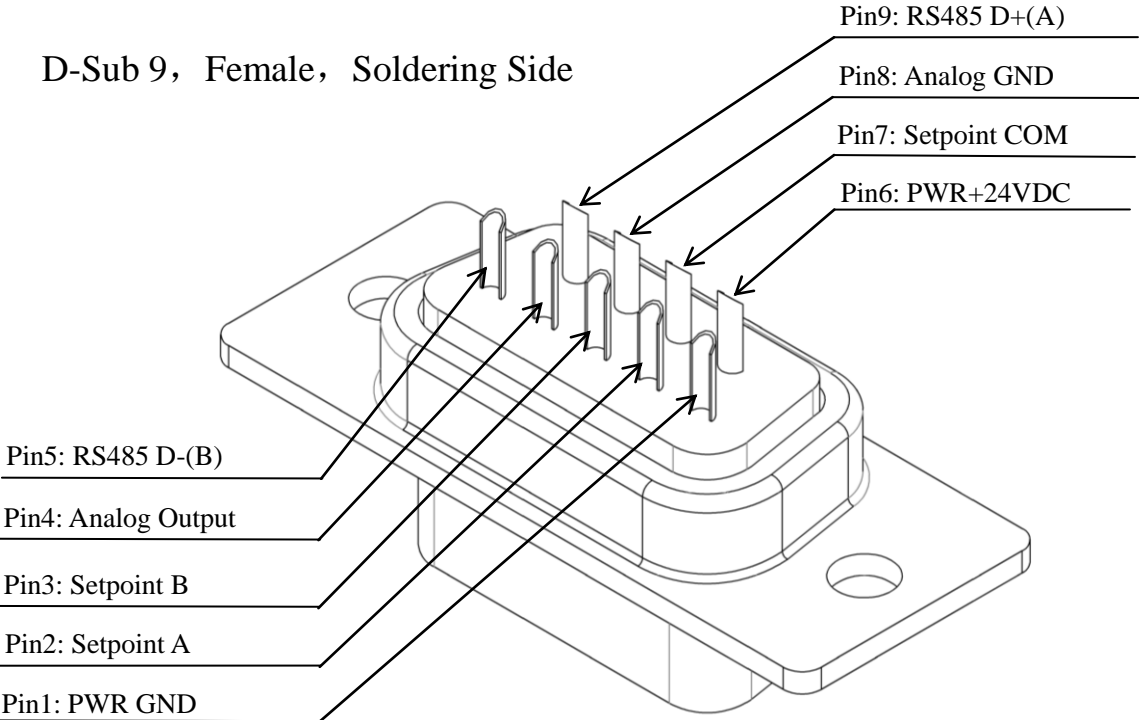

Pay Attention on D-Sub 9: Male, Female, Socket, Soldering Side.

## 4. Analog Signal Output

Pin 4 / Pin 8 of the connector provides the analog voltage value of real-time vacuum pressure.

Measuring Signal Range: +1.8V ~ +10.0VDC, 2.5mV resolution.

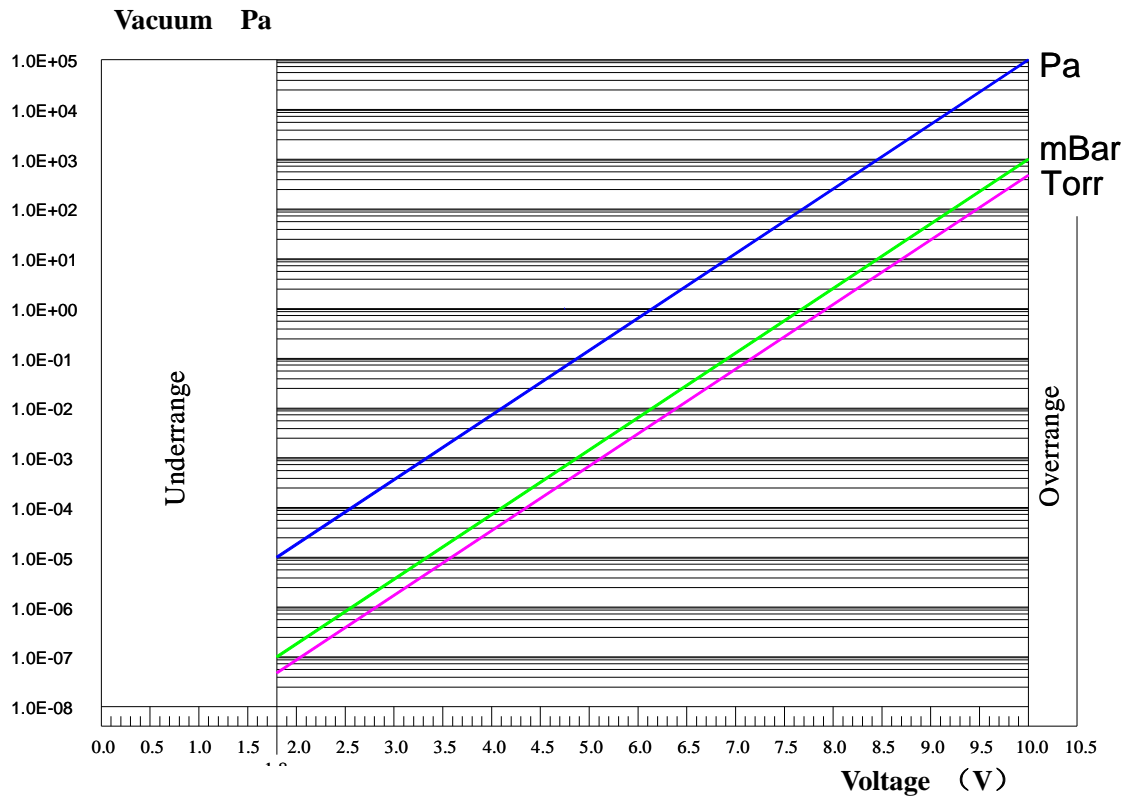

Relationship between analog voltage output signal and vacuum pressure:

$$P = 10^{1.222(U-C)} \iff U = C + 0.818 \lg P$$

Here **P** : Vacuum Pressure  
**U** : Analog Voltage (V)  
**C** : Constant

U	P	C
(V)	Pa	5.909
(V)	mBar	7.545
(V)	Torr	7.647

# 5. Setpoint Switch Setting

WPC400 has two setpoint switches that can be set independently, and the vacuum pressure at the switching point can be set through the top keys

The set value range of the change-over switch is  $5.0e-5 \text{ PA} \sim 9.9e + 4 \text{ PA}$ .

The contact capacity of the relay is 60VDC 0.5A, which is normally open. The setting value is defined as that the relay switches to the on state. When the vacuum pressure is lower than this setting value, the output is "on". When the vacuum pressure rises to 110% of the setting value, the signal output is "off".

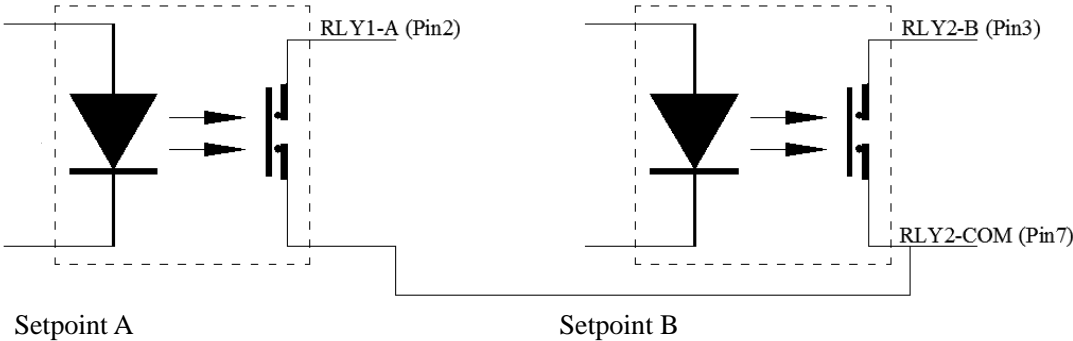

Setpoint Relay Diagram (60VDC/600mA)

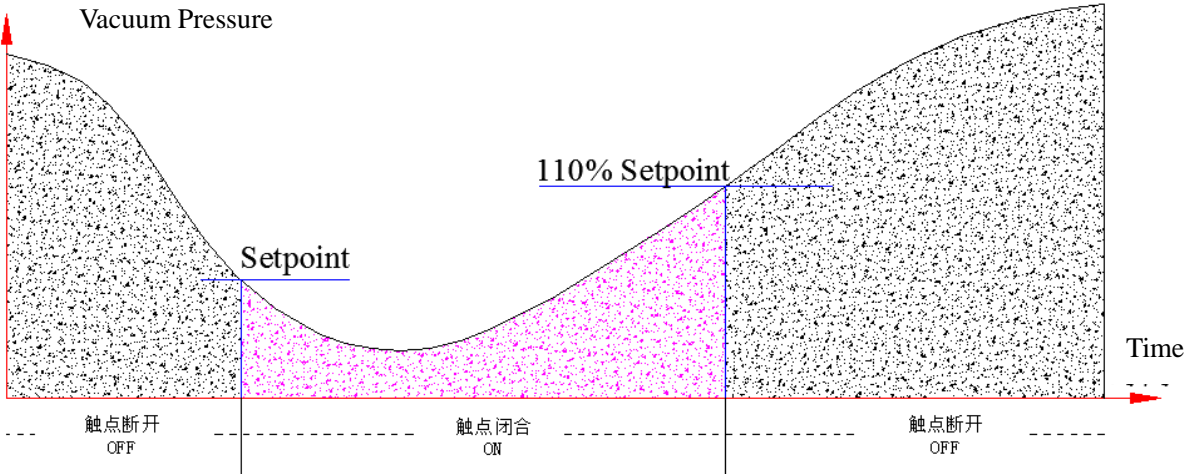

Setpoint Diagram

## 6. Gas Type Dependence

For Pirani portion of WPC400, the measurement is sensitive to the type of gas in the system. The different gases have different masses and hence will take different amounts of heat out of the wire. However, this does mean that if the gauge is calibrated using air or N<sub>2</sub> and is then used to measure a process gas such as Argon, there will be an error in the pressure measurement. The error is reproducible and so in most cases the pressure is accepted as being a relative, but reproducible, measure of pressure.

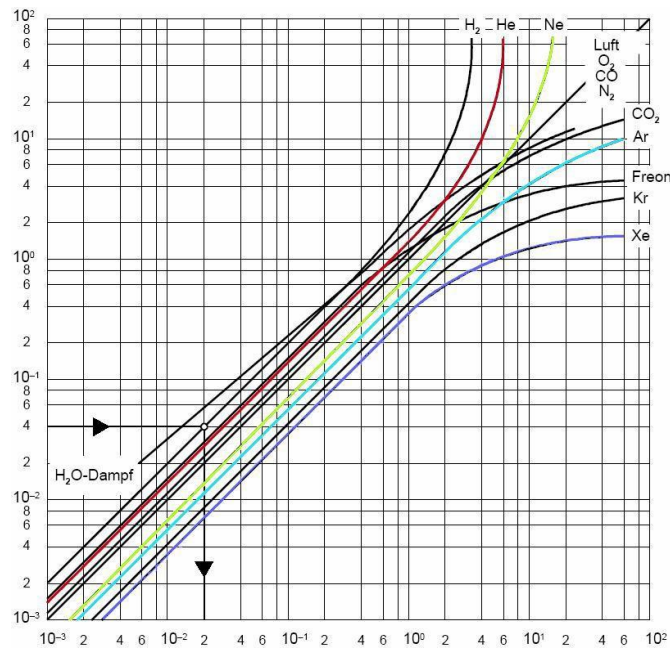

For cold cathode portion of WPC400, the results of vacuum measurement are related to the gas composition, and the relevant correction factors are shown in the table below.

$P_{\text{eff}} = C \times \text{Indicated Pressure}$  Where	Gas Type	Calibration Factor C
	Air, O <sub>2</sub> , CO	1.0
	N <sub>2</sub>	1.0
	He	5.9
	Ne	4.1
	H <sub>2</sub>	2.4
	Ar	0.8
	Kr	0.5
	Xe	0.4

## 7. WPH300 Panel Demonstration

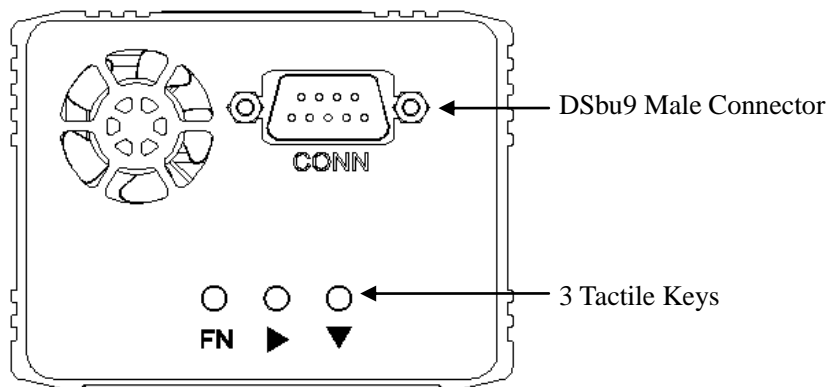
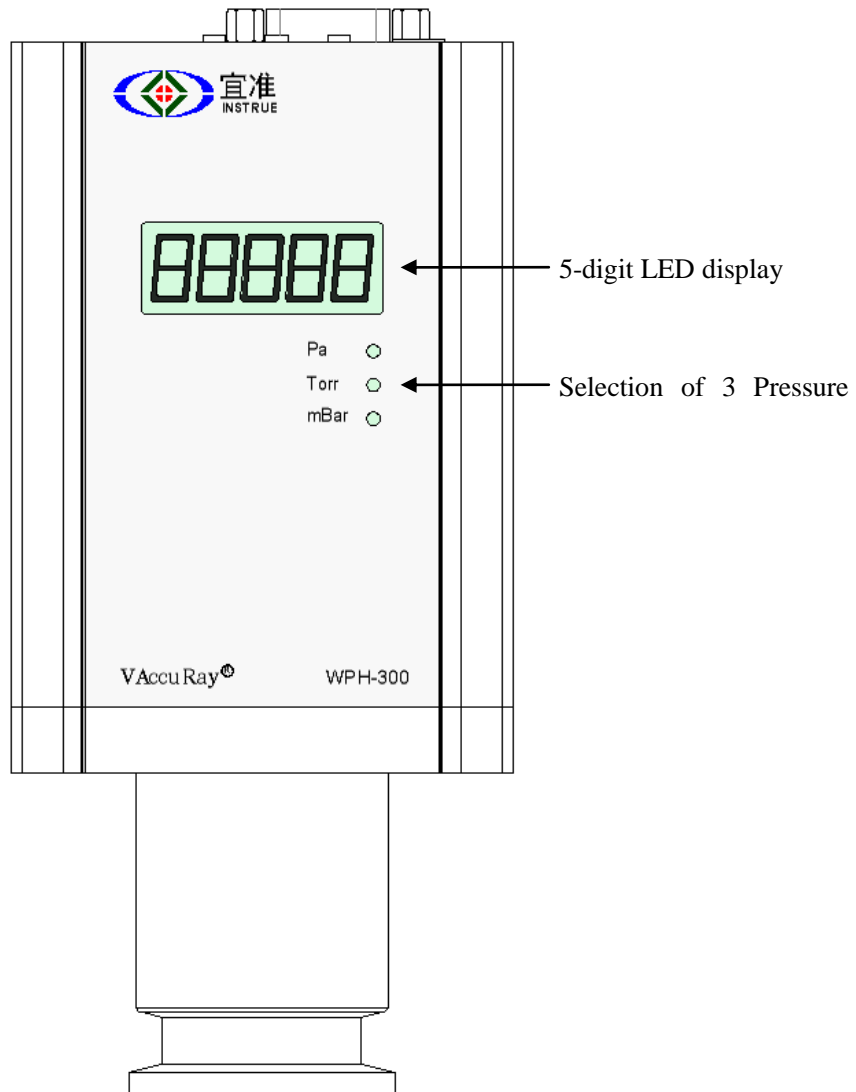

## 8. WPH 300 Key Operation Instructions

MENU Key	Display	▶ Key	▼ Key
Press 1 & Hold	ATP	Press to calibrate atmospheric pressure	NA
Press 2 & Hold	HUC	Press to implement zero calibration	NA
Press 3 & Hold	—	Press to show SP1 value, then press again to flash one digit which can be changed	Press repeatedly to change the flashing number and set the vacuum pressure of the setpoint
Press 4 & Hold	— —	Press to show SP2 value, then press again to flash one digit which can be changed	Press repeatedly to change the flashing number and set the vacuum pressure of the setpoint
Press 5 & Hold	U	Press the display unit repeatedly to select: Pa, Torr, mbar	NA
Press 6 & Hold	d	Press to select the display format. S is the scientific counting format and N is the floating format	NA
Press 7 & Hold	Ad	Press to show the RS485 address on last two digital LED, and then press repeatedly to flash the digit which can be changed.	Press repeatedly to change the current flashing digit setting (0-9). Address 01 ~ 99 can be set.
Press 8 & Hold	AUT	Select whether the Pirani zero is automatically calibrated. Set 1 as automatic calibration that the zero calibration is implemented when ion gauge reaches high vacuum. Set 0 to turn off the automatic zero calibration function.	NA
Press 9 & Hold	dS	DEGAS. Chose ON to prepare to start.	After ▶ ON, Push to start 60sec Degas.
Press 10 & Hold	DFL	Restore the factory settings	NA

## 9. WPH300 Probe Replacement

Affected by the process gas medium and vacuum environment, the Pirani filament and hot cathode filament of WPH300 may be oxidized, aged, corroded and burned out. When the vacuum measurement shows  $1.0e-5\text{Pa}$  in the atmosphere or  $1.0e-5\text{Pa}$  directly after the ion gauge filament is started, consider the filament burnout and detect whether the probe needs to be replaced.

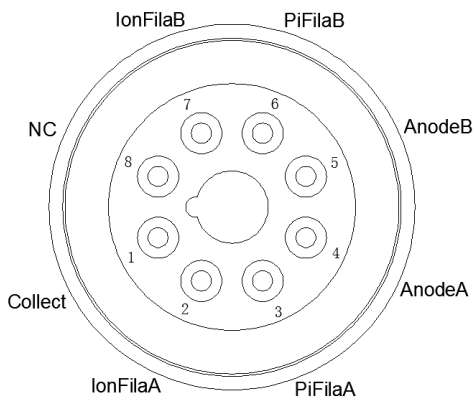

HP027 Pirani/Hot Ion Tube  
Bottom View

If the resistance between the following two pins exceeds the range:

- 1) Pin3 (PiFilaA) and Pin6 (PiFILAB)  $<100\Omega$
- 2) Pin2 (IonFilaA) and Pin7 (IonFILAB)  $<1\Omega$

Then the probe needs to be replaced.

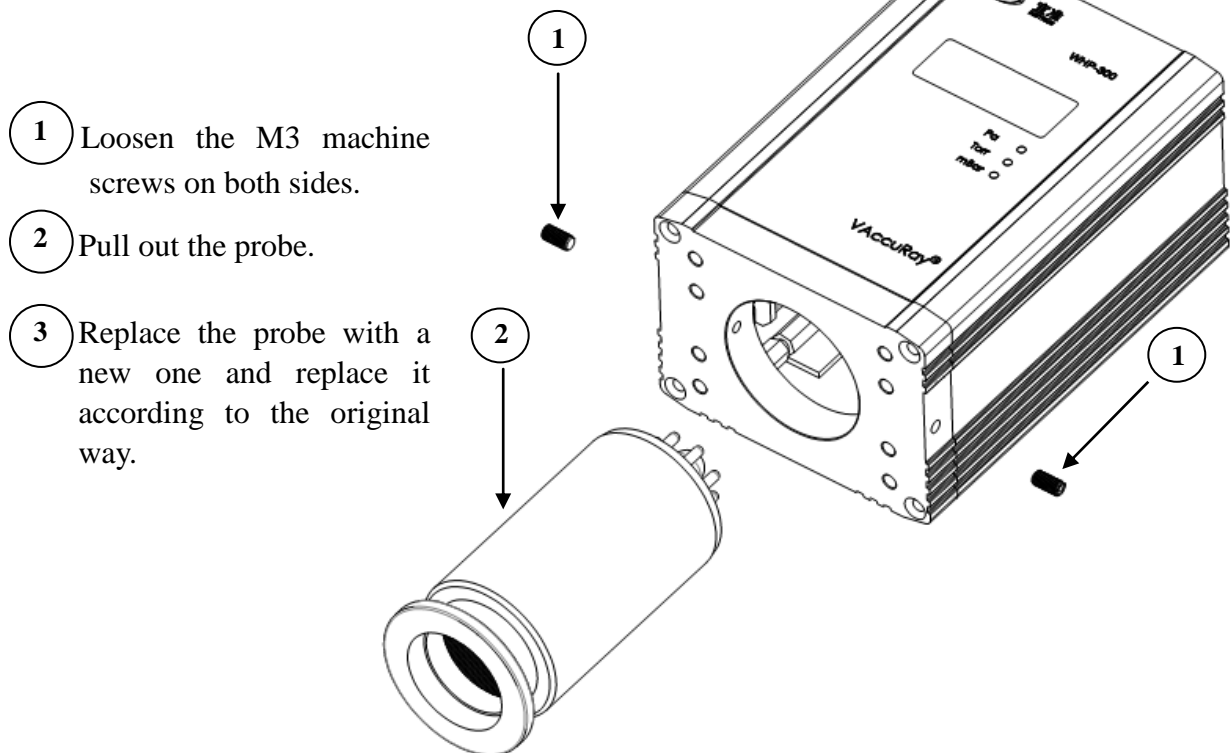

## 10. Installation



When handling vacuum components, take appropriate measures to ensure cleanliness and prevent damages. Ensure that the flange is clean, dry and free of grease.

---

### Vacuum Connection



Overpressure in the vacuum system  $>1.0E+5\text{Pa}$ . If clamps are opened unintentionally, injury can be caused by catapulted parts. Use the type of clamps which can only be opened and closed by means of a tool.

---



The gauge must be electrically connected to the grounded vacuum chamber. For gauges with KF flanges, use a conductive metallic clamping ring.

---

### Mounting orientation

The installation position can be freely selected. The preferred position is a horizontal to vertical position so that condensate and particles do not penetrate the measurement chamber.

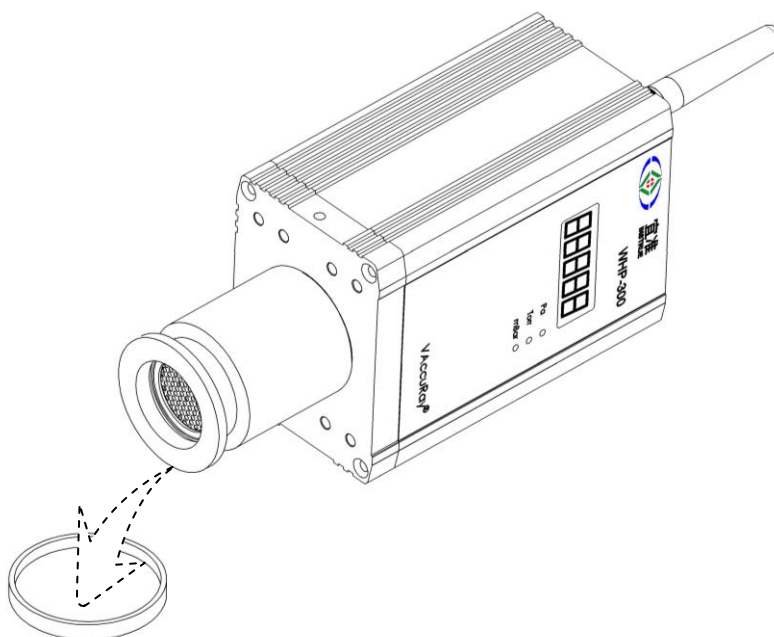

### Procedure

**Step 1.** Remove the protective cover and keep it for maintenance use.

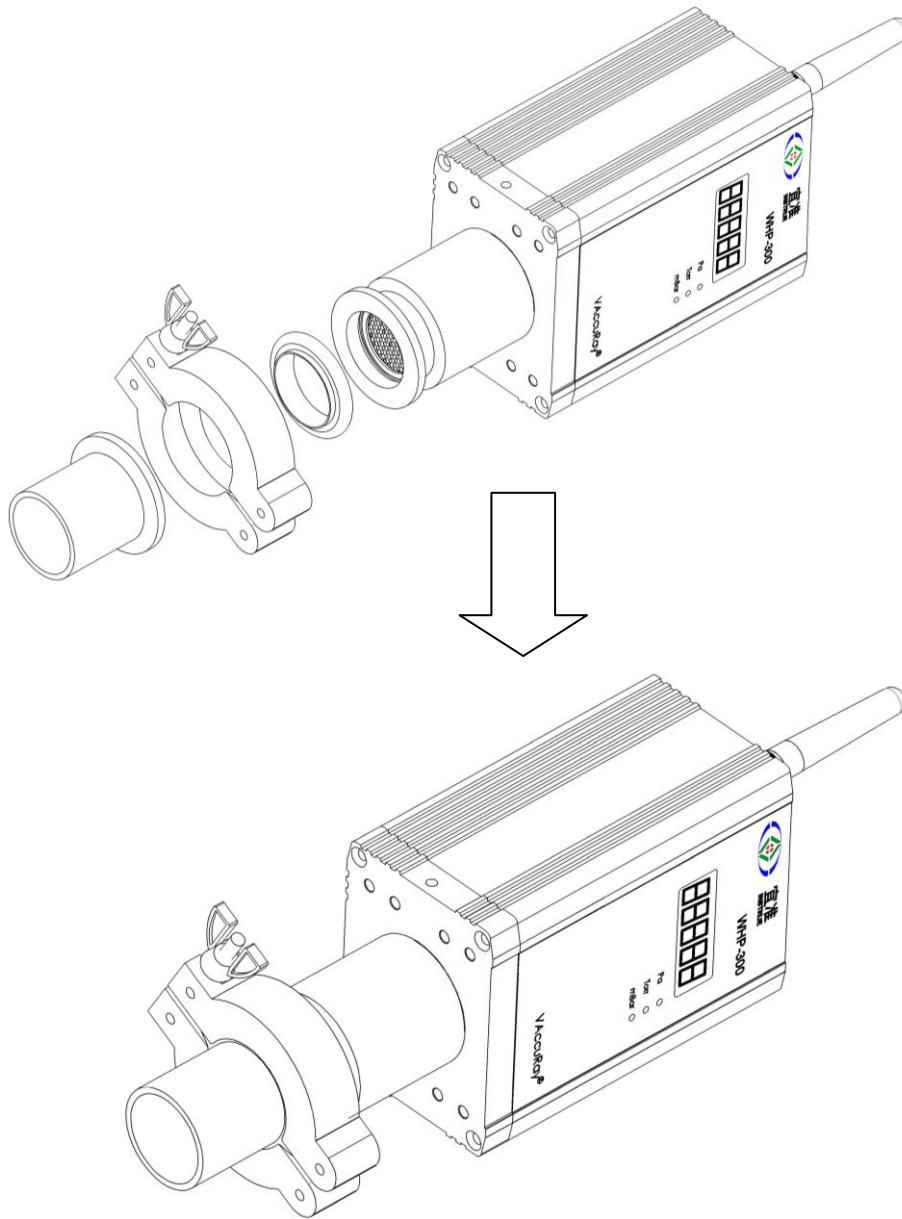

**Step 2.** Make the flange connection to the vacuum system, preferably without applying vacuum grease.



-  When installing the gauge, make sure that the area around the connector is accessible for the tools required for adjustment.
-  When installing the gauge, allow for installing/deinstalling the connectors and accommodation of cable loops.
-  When installing the gauge, make sure that it's easy to read the LED display, and to reach the push buttons.

## 11. WPH 300 Operation

### 11.1 Standalone Mode

WPH-300 has its own LED display and programming keys, only +24VDC is needed to work as an independent vacuum meter.

#### Power Connection

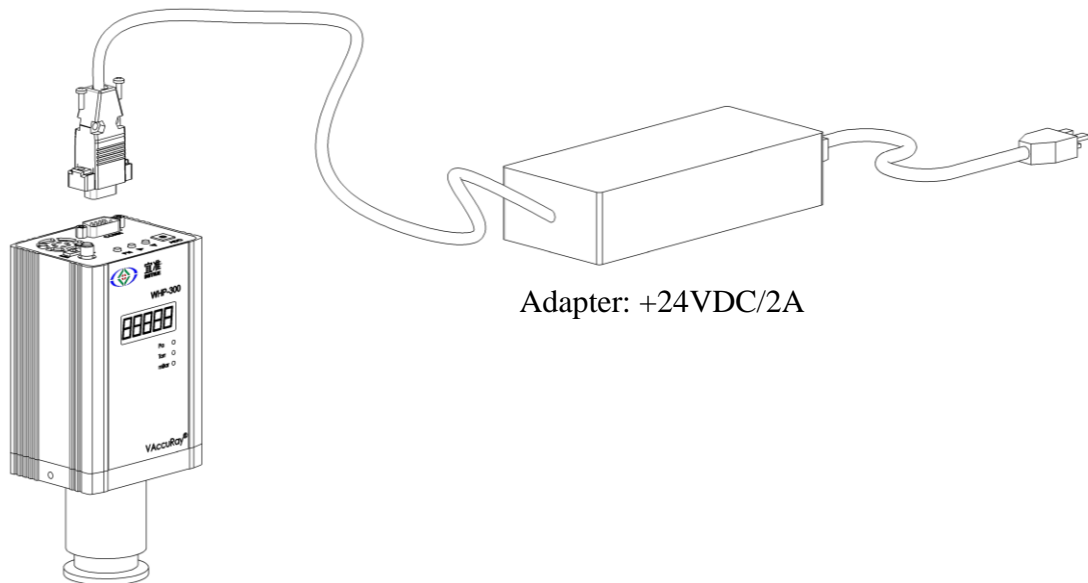

When powered on, the build-in 5-digit LED will display “PH300” for 3 seconds, then start indicating the gauge pressure with format of “8.8E±8”. The default unit is Pascal, although you can select Torr or mBar by three programming keys.

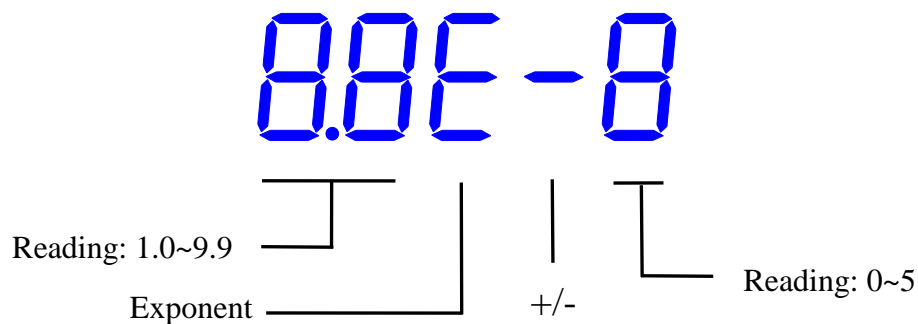

The reading ranges from 1.0E+5 Pa to 1.0E-5 Pa.

## 11.2 Use with INSTRUE WGC 150 Vacuum Gauge Controller

If the WPH-300 is used with an Instrue vacuum gauge controller WGC-150, a corresponding cable is needed. The cable permits supplying the WPH-300 with +24VDC power, transmitting measurement values and gauge statuses, and making parameter settings through RS485.

The cable between WPH300 and WGC150 has several options in length.

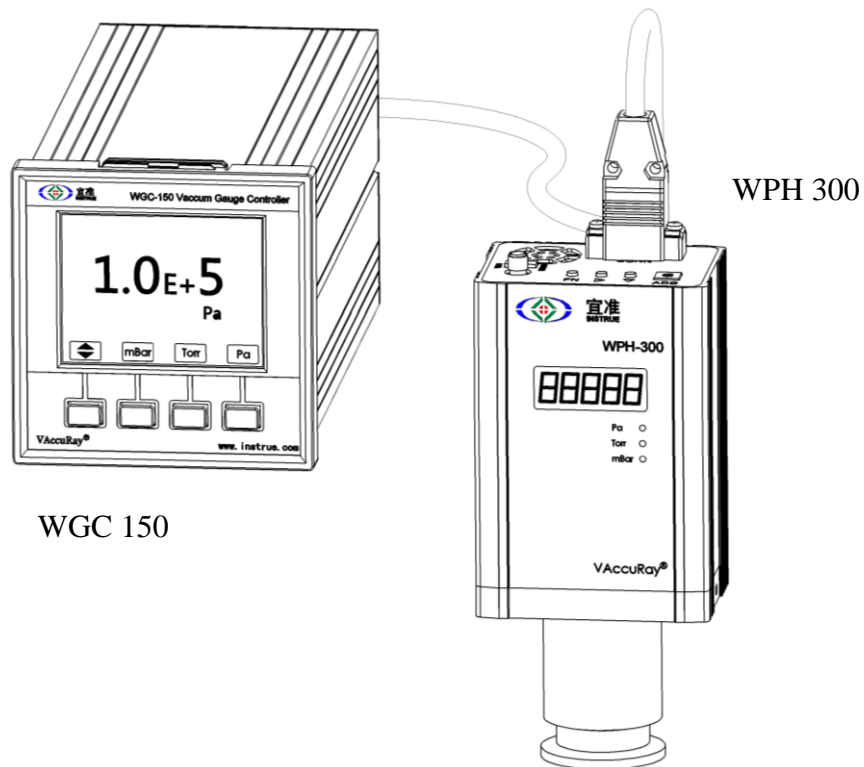
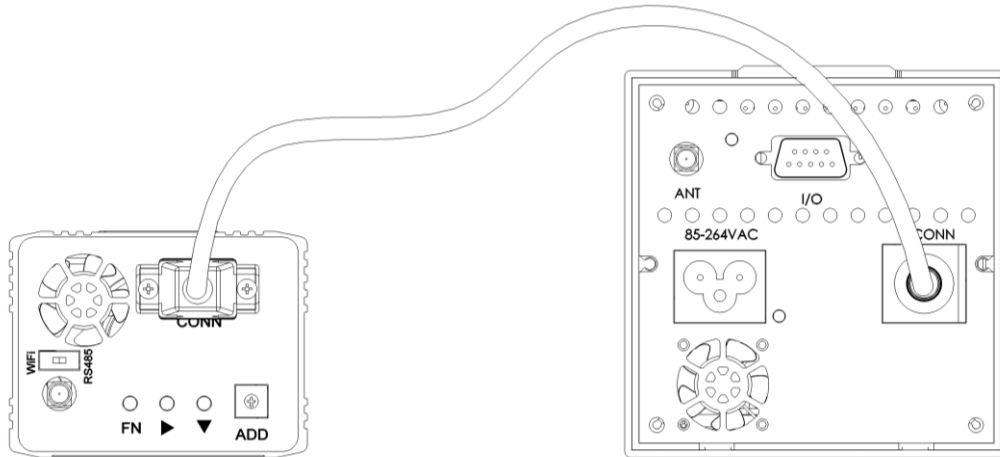

### 11.3 Use with Analog Signal Converter

In the case that a kind of PLC analog module is used to read the pressure, the WPH-300 needs a +24VDC power supply, and D-Sub 9 Pin4 / Pin8 are led to PLC analog input terminals. Here a shielded coaxial cable is strongly recommended.

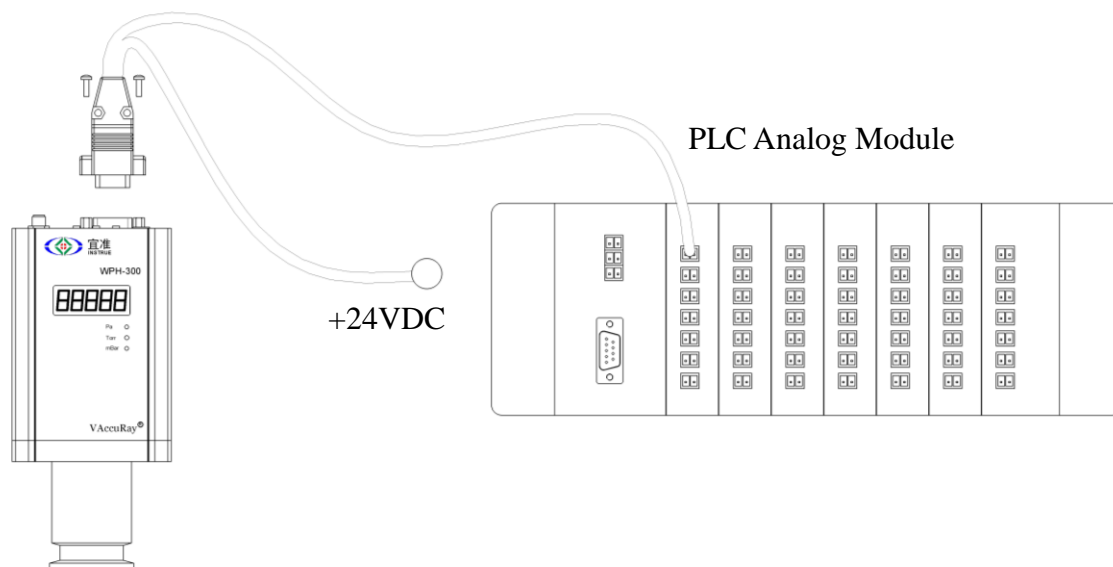

## 11.4 Use with RS485 Communication

Before starting to communicate with the WPH300 via RS485, please be sure to set the ADD corresponding to your system topology design.

The WPH300 can be used with any kind of PLC which has a standard RS485 interface.

The WPH300 can also be used with a regular Win XP\Win7\_32\Win7\_64 based computer, a USB\RS485 converter is normally needed in this case. INSTRUE provides PC software Gauge Reader for this application.

The controlling host sends its commands to the individually addressed devices connected to the RS485 bus. In replay the device returns the data requested via bus to the host.

A maximum of 32 device can be connected to a RS485 bus system.

### Procedure

- Step 1.** A four-wire cable is required to supply the WPH300 with +24VDC\GND, and DATA+\DATA-.
- Step 2.** Install the software driver for RS485\USB converter; and also install the INSTRUE Gauge Reader application software.
- Step 3.** Open the Gauge Reader, click the function selections, then Start.

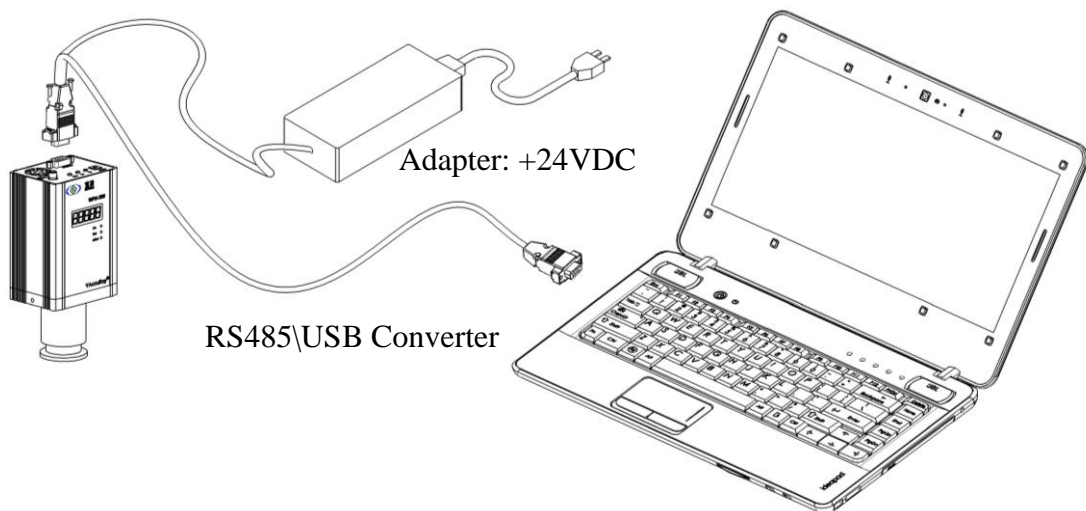

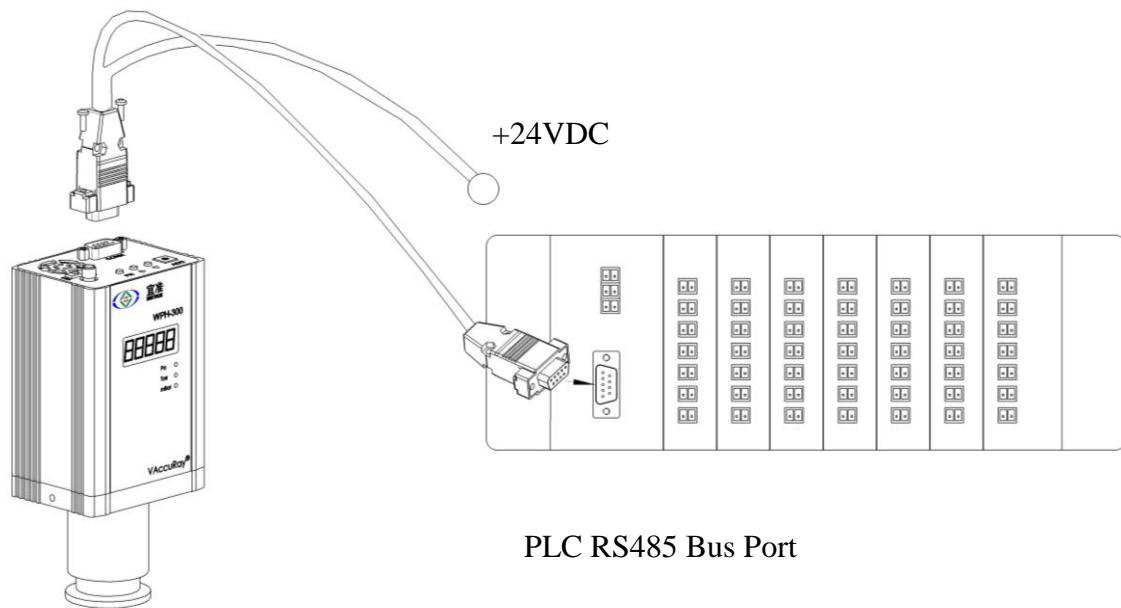

## Operational Parameters

Data Rates: 9600 Baud (other rates are optional)

Byte: 8 data bits

1 stop bit

No parity

Default settings

For those who want to design their own software interface, you need to know the INSTRUE RS485\Wireless communication protocols, and dynamic link libraries, and embed them to your own software.

## 11.5 Gauge Reader Application Software

For use with RS485 and Window based PC, a RS485\USB converter is normally needed. You can follow the coming-with instruction to install a related driver.

For use with wireless transceiver and Window based PC, please install the transceiver USB driver.

### Install USB transceiver driver

- Step 1.** Copy the “IT VacGAuge 2.0” folder to a temporary folder of your computer.
- Step 2.** Plug in the transceiver module in the computer USB port, the computer will pop up a window: Found New Hardware Wizard. Click “Install from a list or specific location”, then Next.



- Step 3** Click Browse and find the IT VacGAuge 2.0 folder, then Next.

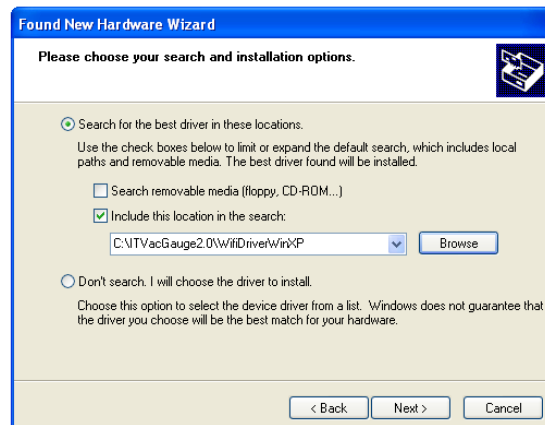

**Step 3.** Click Finish to complete the driver installation.



## Install INSTRUE “Gauge Reader 2.0”

**Step 1.** Double click the file GaugeReader.msi, then Next.



**Step 2.** Click the Browse and find a target folder path you want install the application software, then Next.

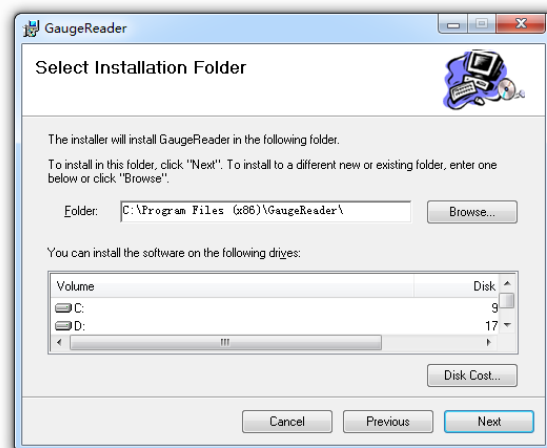

### Step 3. Then Next

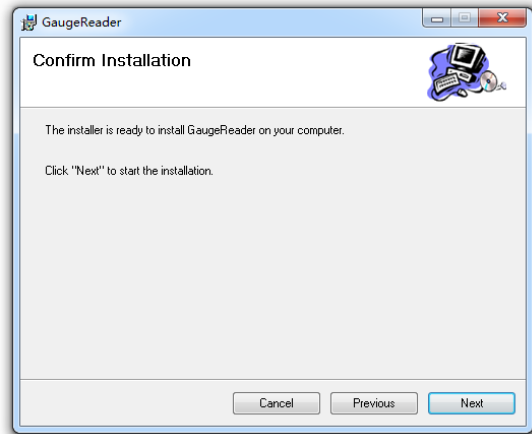

### Start using GaugeReader

Find the file VacGauge.exe in your target folder path, double click, then start to use it.

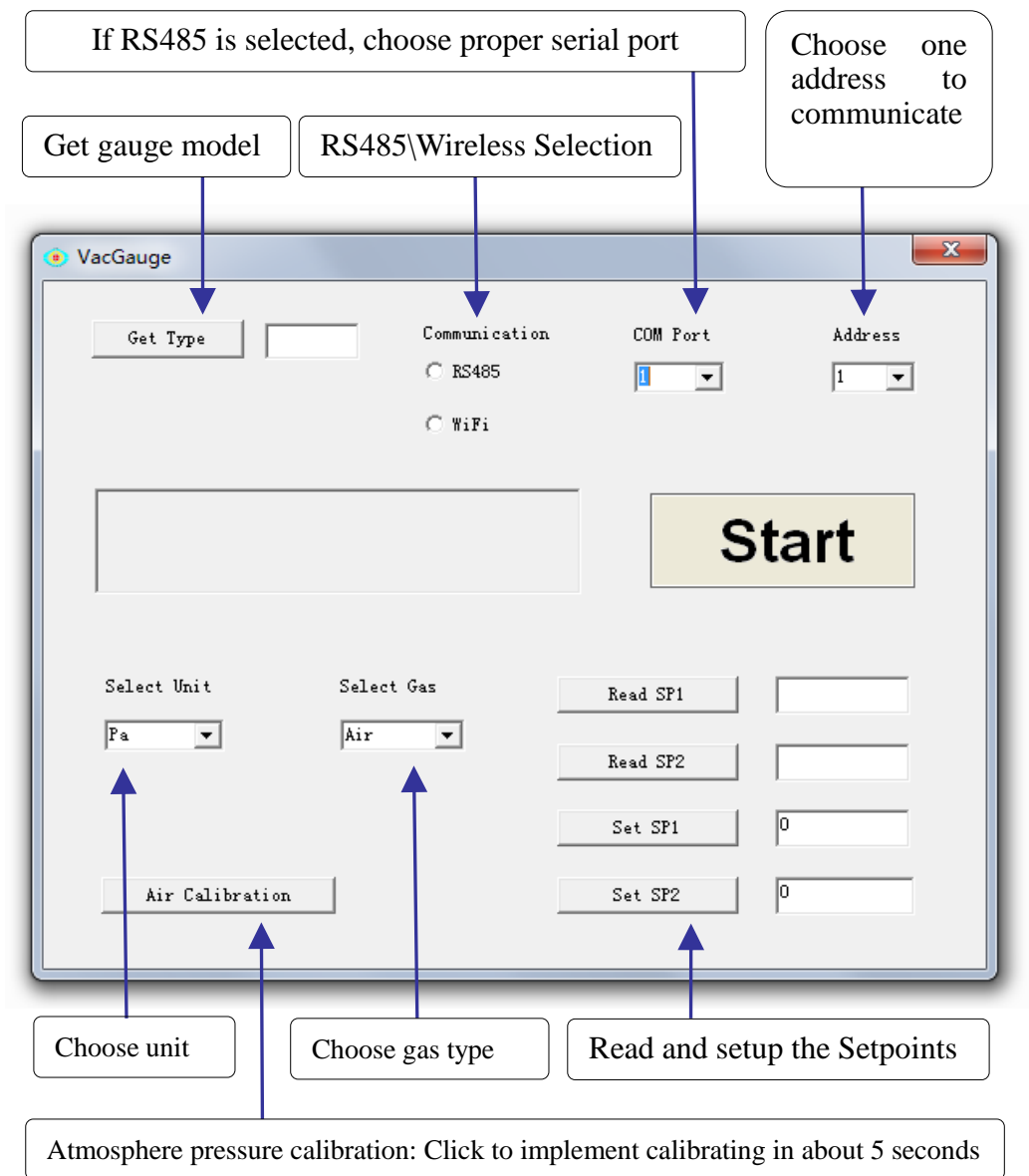

## 12. RS485 MODBUS RTU Communication Protocol

### 1) Series Port Setup:

Baud rate: 9600    Start Bit: 1    Data Bit: 8    Stop Bit: 1  
 Checkout bit: No

### 2) Instruction format:

#### a. Read instruction:

- Upper computer sends instructions to vacuum gauge:

Add	Com mand	Register Hi	Registe r Low	Data Word (Hi 8bit)	Data Word (Low 8bit)	CRC Check (Low8bit)	CRC Check (Hi 8bit)
1-99	03	00	XX	00	XX	XX	XX

- Return Instruction:

Add	Comm and	Data Byte	Data	CRC Check (Low 8bit)	CRC Check (Hi 8bit)
1-99	03	XX	XX Byte	XX	XX

#### b. Write Instruction:

- Upper computer sends instructions to vacuum gauge:

Add	Com mand	Register Hi	Register Low	Data Length (Hi 8bit)	Data Length (Low 8bit)	Data Byte	Highest Data Byte
1-99	16	00	XX	00	02	4	Bit31-24

Data Mid Byte	Data Mid Byte	Data Mid Byte	CRC Check (Low 8bit)	CRC Check (Hi 8bit)
Bit23-16	Bit15-8	Bit7-0	XX	XX

- Return Instruction:

Add	Com mand	Register Hi	Register Low	Data Length (Hi 8bit)	Data Length (Low 8bit)	CRC Check (Low 8bit)	CRC Check (Hi 8bit)
1-99	16	00	XX	00	02	XX	XX

### 3) Register address table:

Register address (16hexadecimal)	Data byte length	Storage content
01	2	Gauge Ch1: Vacuum data of scientific counting format
03	2	Gauge CH2: Vacuum data of scientific counting format
11	2	Gauge Ch1: Vacuum data of floating point format
13	2	Gauge CH2: Vacuum data of floating point format
21	2	Set Point 01: Floating Format
23	2	Set Point 02: Floating Format
25	2	Set Point 03: Floating Format
27	2	Set Point 04: Floating Format
29	2	Set Point 05: Floating Format
2B	2	Set Point 06: Floating Format
31	1	Set Point 01 correspond Gauge 1: Gauge Ch1; 2: Gauge Ch2
32	1	Set Point 02 correspond Gauge 1: Gauge Ch1; 2: Gauge Ch2
33	1	Set Point 03 correspond Gauge 1: Gauge Ch1; 2: Gauge Ch2
34	1	Set Point 04 correspond Gauge 1: Gauge Ch1; 2: Gauge Ch2
35	1	Set Point 05 correspond Gauge 1: Gauge Ch1; 2: Gauge Ch2
36	1	Set Point 06 correspond Gauge 1: Gauge Ch1; 2: Gauge Ch2
40	1	Implement Calibration: 1: Gauge Ch1 atmosphere      2: Gauge Ch1 Zero 4: Gauge Ch2 atmosphere      8: Gauge Ch2 Zero

#### Data display format:

##### Scientific count format

For example, the vacuum gauge display data is 1.2E+3, and the ASCII code stored in the register is the corresponding data, that is, 0x31, 0x32, 0x2b, 0x33.

For example, the vacuum gauge displays the data 1.0E-1, and the data stored in the register are 0x31, 0x30, 0x2d and 0x31.

##### Floating format

The 32 bit floating number is stored in the register.

#### Vacuum gauge address setting:

Through Gauge Reader 3.0 application software interface, you can set the vacuum meter local address, factory address set to 01.

### 13. Dimensions (mm)

