

## Ion/Pirani Vacuum Gauge Operation Manual

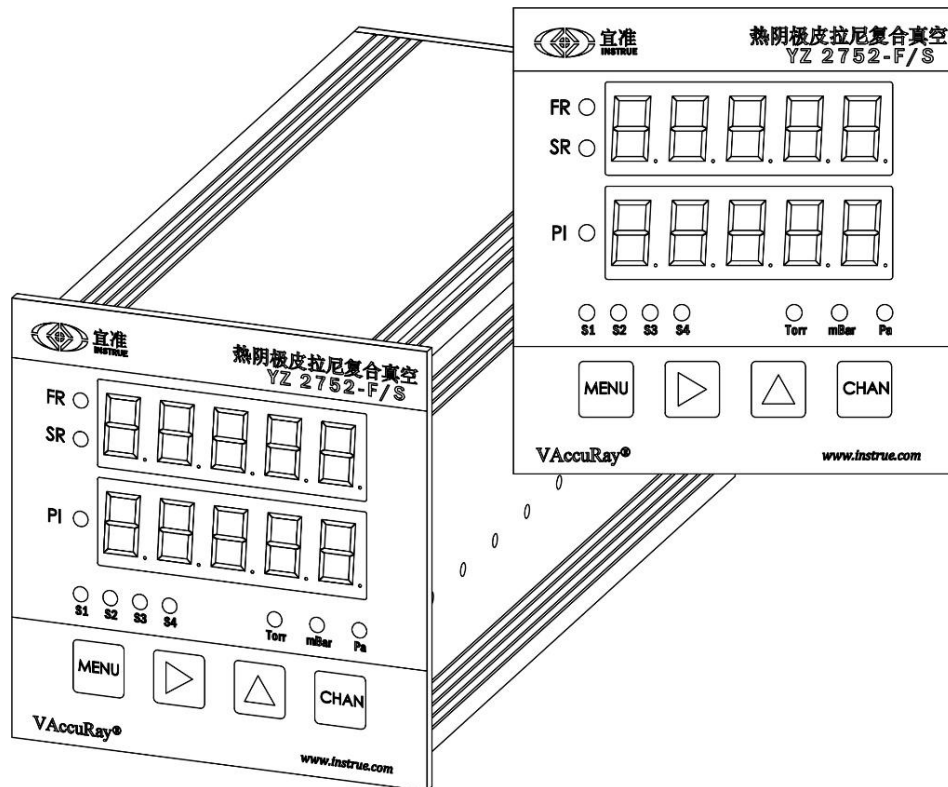

- Intelligent four key operation
- Adaptive three combination configurations
  - ✓ Single channel full range measurement
  - ✓ Full range gauge + Pirani gauge two-channel measurement
  - ✓ Traditional ZJ27 ion tube + ZJ52 Pirani two-channel
- Support RS485 Modbus-RTU communication to collect data and parameters
- Support ion gauge filament external enable
- Support analog voltage output
- Support four (optional six) setpoint control relays

## 1. Introduction

YZ 2752 is a wide range vacuum gauge composited with a hot ion filament and a Pirani convectional filament, and is compatible with traditional ZJ27 ion tube and ZJ52 thermal resistance tube.

This model adopts dual (or single) line LED display. All parameter settings and instrument calibration are completed by four intelligent tactile keys on the front panel. Four channel optical isolation setpoint control relays, logarithmic analog voltage output, RS485 communication transmission, and optional wireless signal transmission function provide a variety of tools for industrial field control.

The use of digital and analog filtering, high fidelity signal transmission, high-voltage signal optical isolation, hardware and software temperature compensation and some unique technologies makes YZ 2752 have outstanding advantages in repeatability, stability, response speed, anti-interference and so on.

This model is widely used in vacuum coating, semiconductor technology, photovoltaic crystal, scientific research and teaching and other fields.

## 2. Selection Guidelines

YZ 2752-XX X X

0: No control relay  
1: Four control relays  
2: Six control relays

0: RS485-Modbus communication  
1: Analog voltage output  
(CH1 for full range gauge output, CH2 for independent Pirani)  
2: RS232 communication  
3: External ion filament enable

FS: Full range single gauge (1.0E-5 ~ 1.0E+5Pa)  
FD: Full range + Pirani dual gauges (1.0E+5 ~ 1.0E+5Pa 与 1.0E-1Pa ~ 1.0E+5Pa)  
GD: Ion + Pirani dual gauges (1.0E-5~1.0Pa 与 1.0E-1 ~ 1.0E+5Pa)  
CM: Customized models

### 3. YZ2752 to be used in different ways

There are three ways to configure the ECU and sensor probes. The YZ2752 software will recognize the sensor type and automatically run the corresponding functions.

#### 3.1 YZ2752-FS Full Range Single Probe

Measurement Range:  $1.0E-5 \sim 1.0E+5Pa$  (Atmosphere)

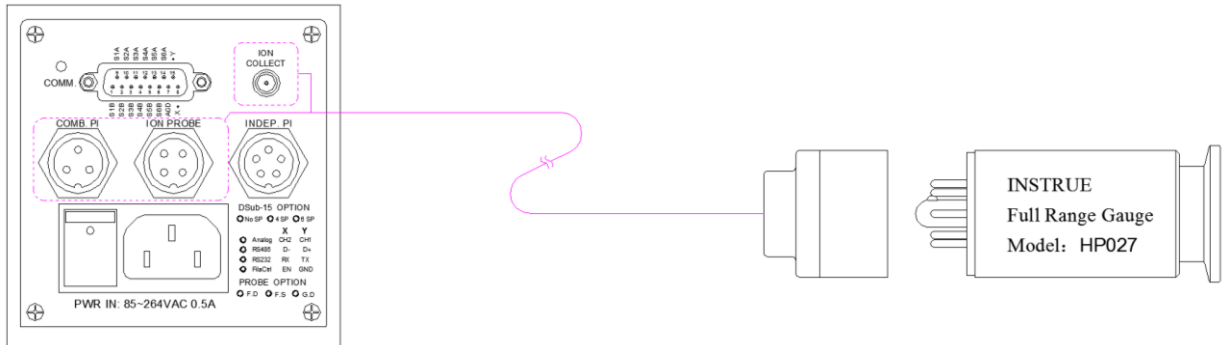

#### 3.2 YZ2752-FD Full Range Dual Probe

Full Range Measurement:  $1.0E-5 \sim 1.0E+5Pa$  (Atmosphere)

Pirani Measurement Range:  $1.0E-1 \sim 1.0E+5Pa$  (Atmosphere)

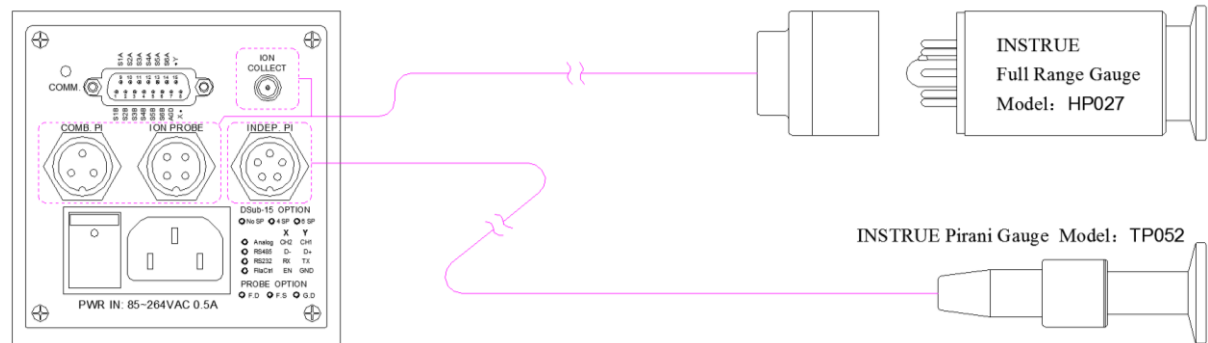

#### 3.3 YZ2752-GD Hot Ion Gauge and Thermal Gauge Dual Probe

Ion tube Enables filament when Pirani's pressure lower than 1.0Pa.

Ion Gauge Measurement Range:  $1.0E-5 \sim 1.0Pa$

Thermal Gauge Measurement:  $1.0E-1 \sim 1.0E+5Pa$  (Atmosphere)

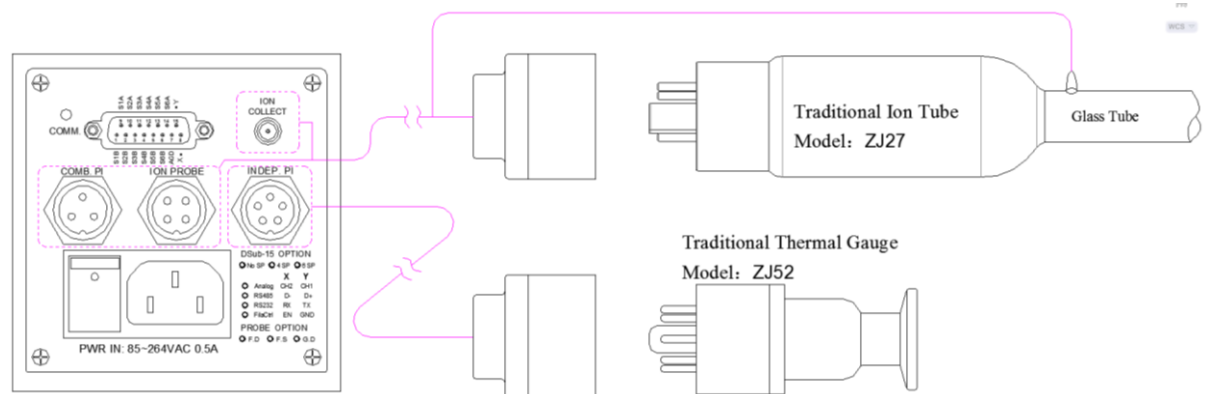

## 4. Specifications

Parameters	Technical Data																									
Measurement Range	1.0×10 <sup>-5</sup> ~ 1.0×10 <sup>+5</sup> Pa (Air, N2)																									
Accuracy	1.0×10 <sup>-5</sup> ~ 1.0×10 <sup>-4</sup> Pa : ±35% 1.0×10 <sup>-4</sup> ~ 1.0×10 <sup>+4</sup> Pa : ±25% 1.0×10 <sup>+4</sup> ~ 1.0×10 <sup>+5</sup> Pa : ±50%																									
Repeatability	1.0×10 <sup>-5</sup> ~ 1.0×10 <sup>+3</sup> Pa : ±5% 1.0×10 <sup>+3</sup> ~ 1.0×10 <sup>+5</sup> Pa : ±25%																									
Max. Pressure	1.5×10 <sup>+5</sup> Pa																									
Response Time	< 100 ms																									
Work Environment	-5° C ~ +45° C; 5 ~ 85 %, No condensation																									
Storage Environment	-40° C ~ +80° C; 5 ~ 90 %, No condensation																									
Signal Outputs	Dual (or Single) row 5-digit LED display, with optional units of Pa, Torr and mBar, and four srtpoint indication																									
	Support RS485, 9600 bps, Modbus RTU (Standard)																									
	Support four (optional six) control relay output 60VDC 0.5A ()																									
	Support analog output + 0.0v ~ + 10.0vdc (optional)																									
	Support external enable ion gauge filament (optional)																									
	Support data communication with PC application GaugeReader																									
Power Supply	85 ~ 265VAC, 50 ~ 60Hz, 0.5A; Power consumption Max 35W; (the PIN of earth terminal must be reliably grounded!)																									
Weight and Size	<1Kg (cable and tube not included), 100H X 98W X170L mm <sup>3</sup>																									
Installation Cutting-off	91 <sup>+0.2</sup> mm × 91 <sup>+0.2</sup> mm																									
Analog Voltage Output Equation  P: Pressure U: Voltage C: Constant	Full range or ion gauge channel output  $P=10^{1.222(U-C)}$ $U=C+0.818\lg P$	Independent Pirani gauge channel output  $P=10^{((U-c)/1.286)}$ $U=c+1.286X\lg P$																								
	<table border="1"> <thead> <tr> <th>U</th> <th>P</th> <th>C</th> </tr> </thead> <tbody> <tr> <td>(V)</td> <td>Pa</td> <td>5.909</td> </tr> <tr> <td>(V)</td> <td>mBar</td> <td>7.545</td> </tr> <tr> <td>(V)</td> <td>Torr</td> <td>7.647</td> </tr> </tbody> </table>	U	P	C	(V)	Pa	5.909	(V)	mBar	7.545	(V)	Torr	7.647	<table border="1"> <thead> <tr> <th>U</th> <th>P</th> <th>C</th> </tr> </thead> <tbody> <tr> <td>(V)</td> <td>Pa</td> <td>3.572</td> </tr> <tr> <td>(V)</td> <td>mBar</td> <td>6.143</td> </tr> <tr> <td>(V)</td> <td>Torr</td> <td>6.304</td> </tr> </tbody> </table>	U	P	C	(V)	Pa	3.572	(V)	mBar	6.143	(V)	Torr	6.304
	U	P	C																							
	(V)	Pa	5.909																							
	(V)	mBar	7.545																							
	(V)	Torr	7.647																							
U	P	C																								
(V)	Pa	3.572																								
(V)	mBar	6.143																								
(V)	Torr	6.304																								

## 5. Front Panel Operation

### 5.1 Two probe two row display panel

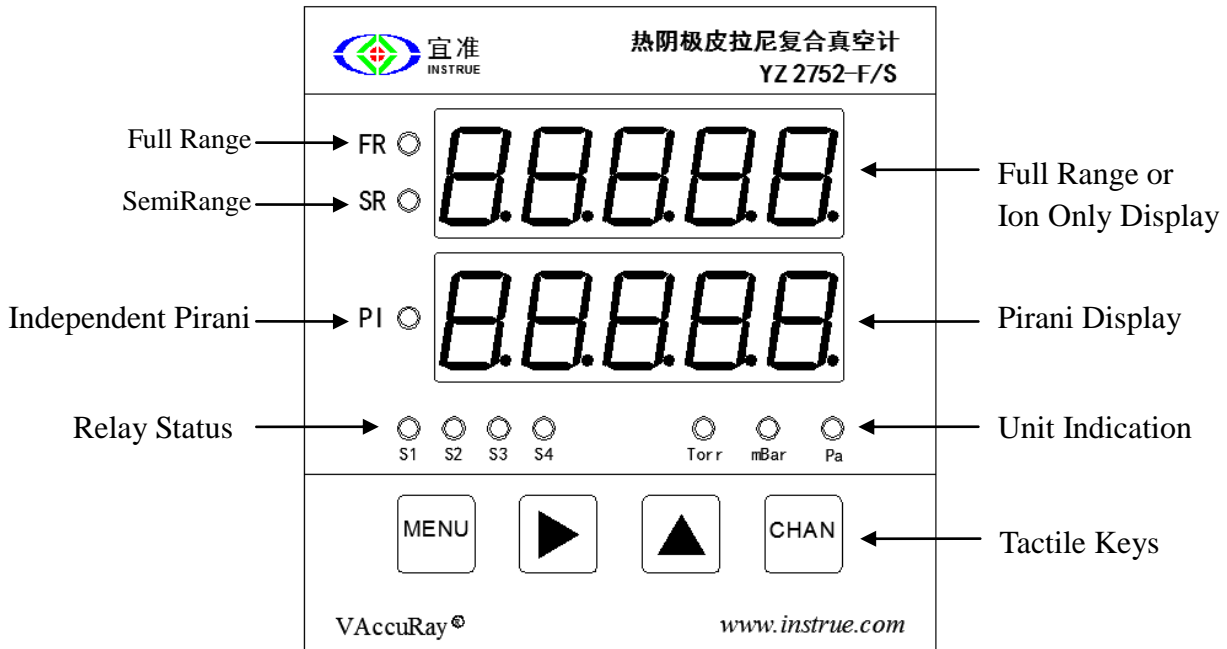

### 5.2 Single Probe Single Row Display Panel (Only for YZ2752-FS)

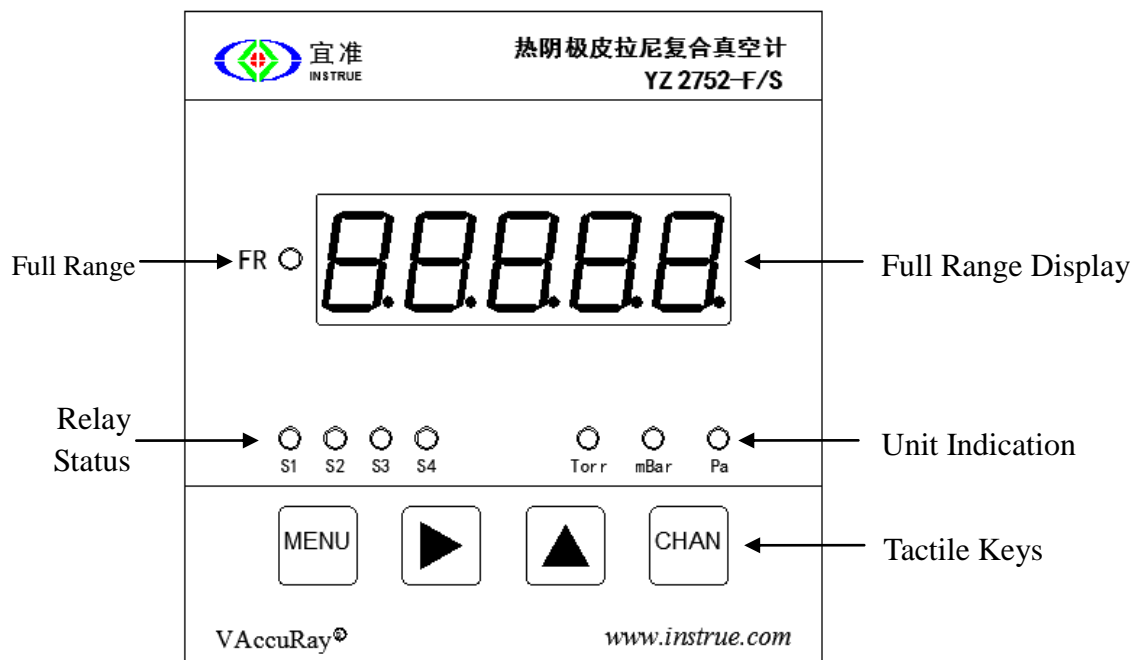

### 5.3 Key Operation Instructions

MENU	Display	 Key	 Key	CHAN Key
1	ATP1	Channel 1 atmosphere calibration	NA	NA
2 *	ATP2	Channel 2 atmosphere calibration	NA	NA
3	HUC1	Channel 1 high vacuum calibration	NA	NA
4*	HUC2	Channel 2 high vacuum calibration	NA	NA
5**	SP1	Select digit to change for setpoint value S1	Set value for current selected digit (0-9)	Choose target channel for relay S1
6**	SP2	Select digit to change for setpoint value S2	Set value for current selected digit (0-9)	Choose target channel for relay S2
7**	SP3	Select digit to change for setpoint value S3	Set value for current selected digit (0-9)	Choose target channel for relay S3
8**	SP4	Select digit to change for setpoint value S4	Set value for current selected digit (0-9)	Choose target channel for relay S4
9	U	Select unit for display: Pa、Torr、mBar	NA	NA
10	Ad	The RS485 address	Set the address number	NA
11	DFL	Restore factory settings.	NA	NA
12****	Fr	Force to ENABLE ion filament, still need to confirm after ON.	NA	Push to turn ON the ion filament.
13*****	AUT	Select the automatic Pirani zero calibration. Set 1 as the zero calibration when ion gauge reaches high vacuum. Set 0 to turn off the automatic zero calibration.	NA	NA
14	dS	DEGAS. Chose ON to prepare to start.	NA	After  ON, Push to start 60sec Degas.

- 1) \* Shown on 2<sup>nd</sup> row when two channel configuration is chosen.
- 2) \*\* High & Low interval setup mode is optional, pls. confirm when order.
- 3) \*\*\* Only appearance when first channel is ion gauge alone.
- 4) \*\*\*\* Only appearance when first channel is full range gauge.

## 6. Rear Panel Operation

### 6.1 Rear Panel

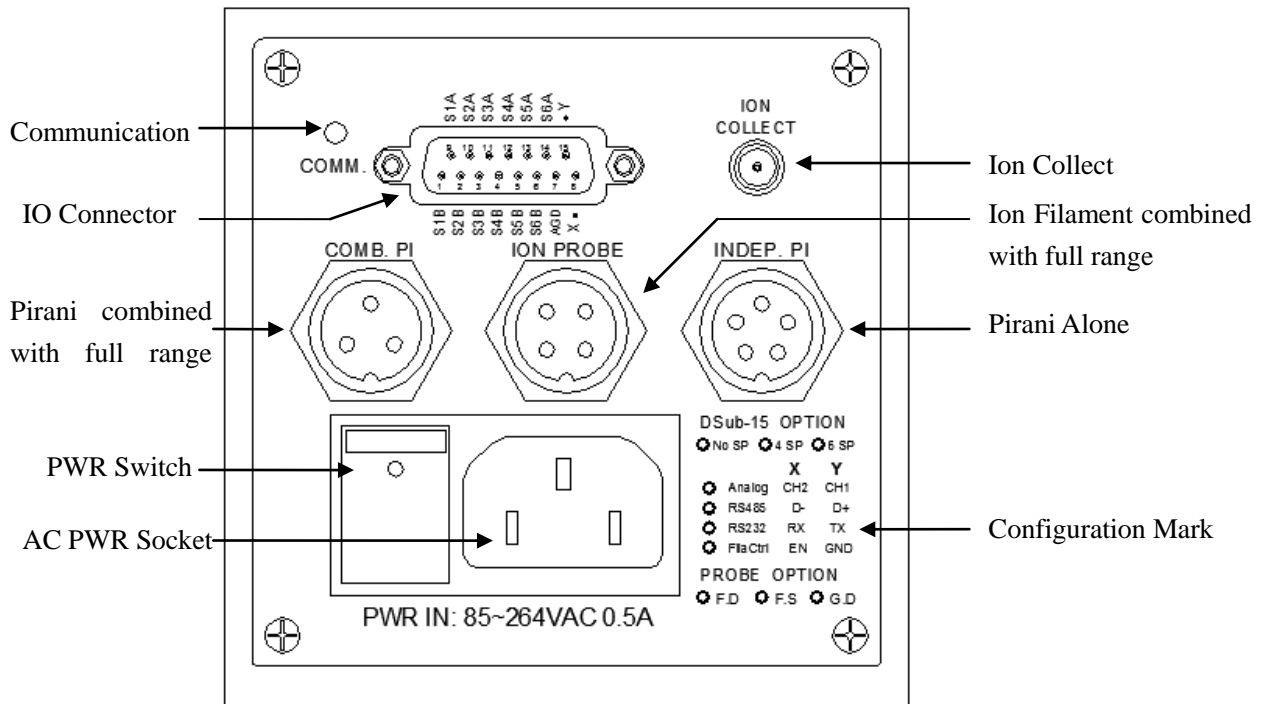

### 6.2 Connector of Pirani with Combined Gauge

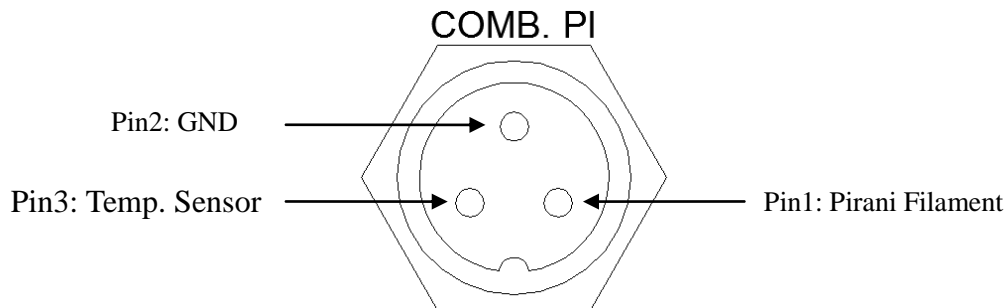

### 6.3 Ion Gauge Connector

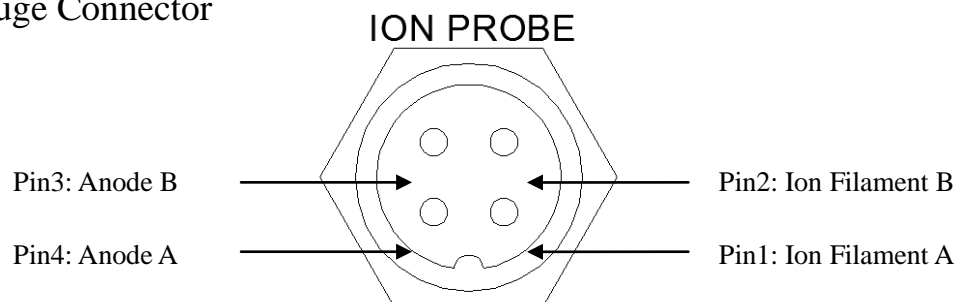

## 6.4 Connector of Pirani Alone

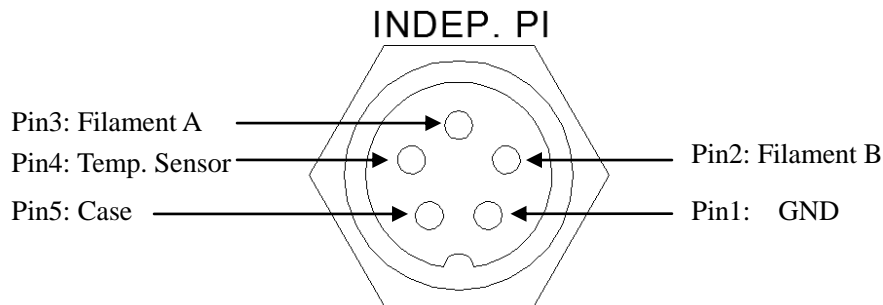

## 6.5 DB15 (Female) I/O Connector

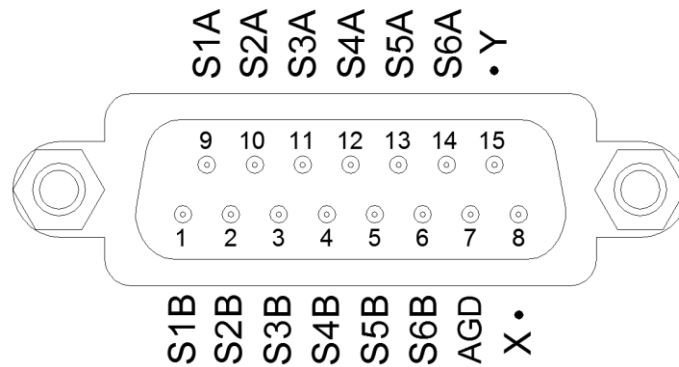

### IO Pin Definition:

Pin 1	Relay output Pin-CH1B	Pin 9	Relay output Pin-CH1A
Pin 2	Relay output Pin-CH2B	Pin 10	Relay output Pin-CH2A
Pin 3	Relay output Pin-CH3B	Pin 11	Relay output Pin-CH3A
Pin 4	Relay output Pin-CH4B	Pin 12	Relay output Pin-CH4A
Pin 5	Relay output Pin-CH5B	Pin 13	Relay output Pin-CH5A
Pin 6	Relay output Pin-CH6B	Pin 14	Relay output Pin-CH6A
Pin 7	AGND	Pin 15	Y: Selectable(DFLT: RS485D+)
Pin 8	X: Selectable (DFLT: RS485D-)		

### X and Y selection (To be confirmed at the time of order)

	X	Y	
⊙ Analog	CH2	CH1	Analog Voltage Output, CH2: Pirani Alone CH1: Full Range or Ion Gauge
⊙ RS485	D-	D+	RS485 Communication
⊙ RS232	RX	TX	RS232 Communication
⊙ FilaCtrl	EN	GND	External Filament ENABLE, X to GND for device control itself, NC for disable

## 7. Setpoint Relay Setting

YZ2752 has four solid state relays that can be set independently, and the vacuum pressure at the switching point can be set through the four keys on front panel.

The contact capacity of the relay is 60VDC 0.5A.

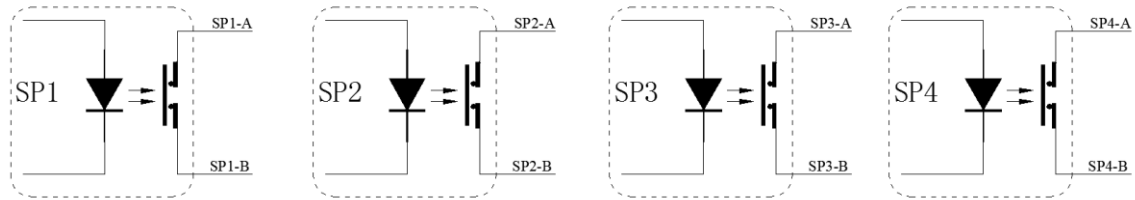

4-Channel Solid State Relay Control

There are two ways to set relay control points. 1) single point control mode and 2) dual-point interval control mode. The standard configuration is single-point control mode. If dual-point interval control mode is needed, please confirm it when ordering.

### 1) Single point control mode

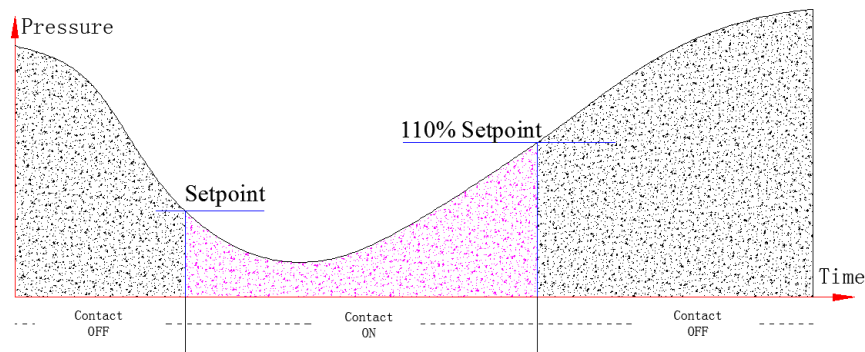

Single Point Control Setting

### 2) Dual-point interval control mode

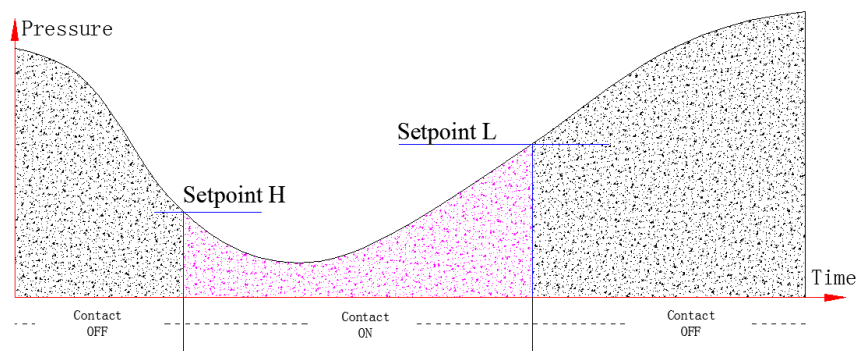

Dual Point Interval Control Setting

## 8. Series Port Communication Protocol

### 1) Communication Setup:

Baud rate: 9600    Start Bit: 1    Data Bit: 8    Stop Bit: 1    Checkout bit: No

### 2) Instruction format:

#### a. Read instruction:

##### ● Upper computer sends instructions to vacuum gauge :

Add	Com mand	Register Hi	Register Low	Data Word (Hi 8bit)	Data Word (Low 8bit)	CRC Check (Low 8bit)	CRC Check (Hi 8bit)
1-99	03	00	XX	00	XX	XX	XX

##### ● Return Instruction:

Add	Command	Data Byte	Data	CRC Check (Low 8bit)	CRC Check (Hi 8bit)
1-99	03	XX	XX Byte	XX	XX

#### b. Write Instruction:

##### ● Upper computer sends instructions to vacuum gauge :

Add	Com mand	Register Hi	Register Low	Data Length (Hi 8bit)	Data Length (Low 8bit)	Data Byte	Highest Data Byte
1-99	16	00	XX	00	02	4	Bit31-24

Data Mid Byte	Data Mid Byte	Data Mid Byte	CRC Check (Low 8bit)	CRC Check (Hi 8bit)
Bit23-16	Bit15-8	Bit7-0	XX	XX

##### ● Return Instruction:

Add	Com mand	Register Hi	Register Low	Data Length (Hi 8bit)	Data Length (Low 8bit)	CRC Check (Low 8bit)	CRC Check (Hi 8bit)
1-99	16	00	XX	00	02	XX	XX

### 3) Register address table :

Register address (16hexadecimal)	Data byte length	Storage content
01	2	Gauge Ch1: Vacuum data of scientific counting format
03	2	Gauge CH2: Vacuum data of scientific counting format
11	2	Gauge Ch1: Vacuum data of floating point format
13	2	Gauge CH2: Vacuum data of floating point format
21	2	Set Point 01: Floating Format
23	2	Set Point 02: Floating Format
25	2	Set Point 03: Floating Format
27	2	Set Point 04: Floating Format
29	2	Set Point 05: Floating Format
2B	2	Set Point 06: Floating Format
31	1	Set Point 01 correspond Gauge 1: Gauge Ch1; 2: Gauge Ch2
32	1	Set Point 02 correspond Gauge 1: Gauge Ch1; 2: Gauge Ch2
33	1	Set Point 03 correspond Gauge 1: Gauge Ch1; 2: Gauge Ch2
34	1	Set Point 04 correspond Gauge 1: Gauge Ch1; 2: Gauge Ch2
35	1	Set Point 05 correspond Gauge 1: Gauge Ch1; 2: Gauge Ch2
36	1	Set Point 06 correspond Gauge 1: Gauge Ch1; 2: Gauge Ch2
40	1	<b>Implement Calibration:</b> 1: Gauge Ch1 atmosphere    2: Gauge Ch1 Zero 4: Gauge Ch2 atmosphere    8: Gauge Ch2 Zero

a. Scientific count format:

For example, the vacuum gauge display data is 1.2E+3, and the ASCII code stored in the register is the corresponding data, that is, 0x31, 0x32, 0x2b, 0x33.

For example, the vacuum gauge displays the data 1.0E-1, and the data stored in the register are 0x31, 0x30, 0x2d and 0x31.

b. Floating format:

The 32 bit floating number is stored in the register.

c. Vacuum gauge address setting:

Through Gauge Reader 3.0 application software interface, you can set the vacuum meter local address, factory address set to 01.

## 9. Electric Control Unit Installation

The cutting-off of cabinet panel is shown in the figure:  $91.0 \times 91.0 \text{mm}^2$ . Insert YZ 2752 through the square hole then fixed with stainless steel clamps from both sides, lock it with two M4 screws.

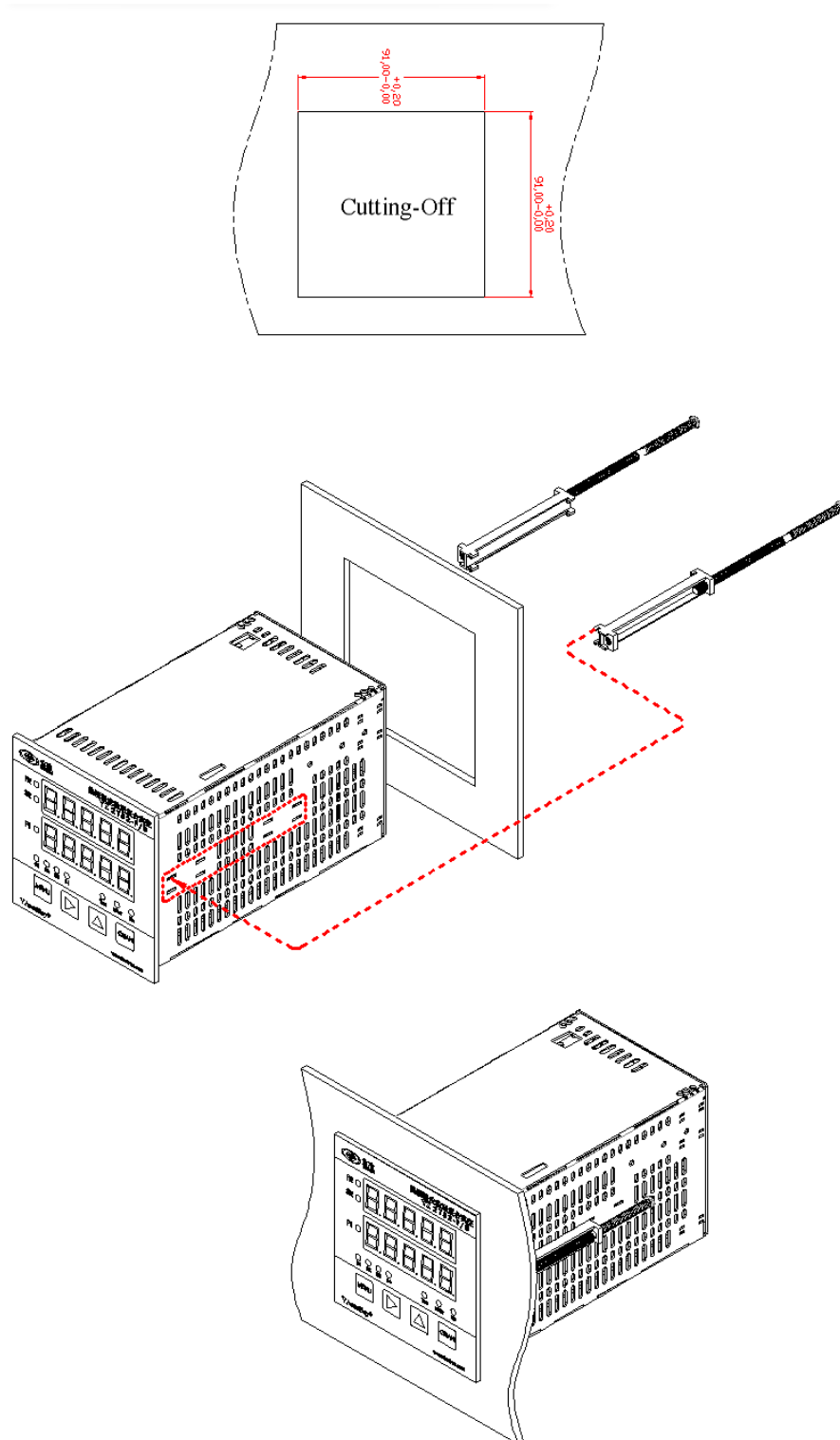

## 10. Dimensions (mm)

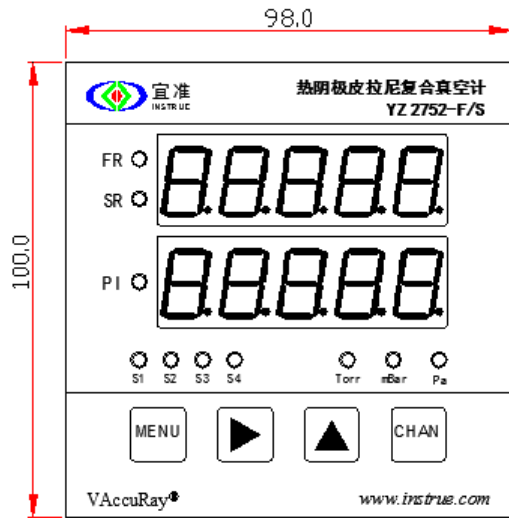

Front Panel

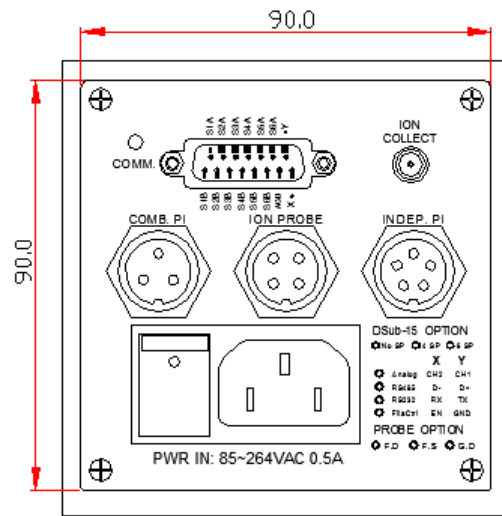

Rear Panel

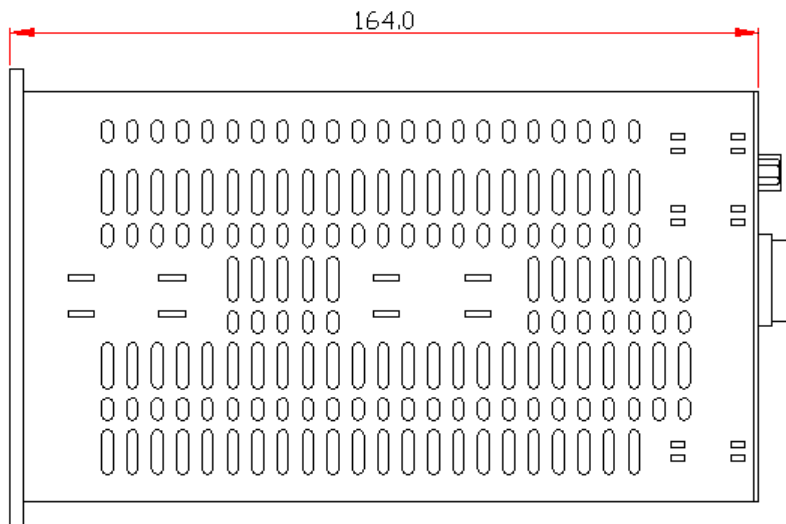

Side View

